



# ELFPRO200 Ventilation Fan

Product Data Sheet

## DESCRIPTION:

Higher performance with less noise! 200mm Pro High Performance, Two Speed Mixed Flow fan for supply and extract ventilation.

## TECHNICAL DATA:

- Air flow capacity of up to 1050m<sup>3</sup>hr
- Designed for continuous operation and equipped with thermal overheating protection
- Suitable for supply and extract ventilation for premises requiring high pressure, powerful airflow and low noise level
- Modern design and aesthetic look
- Single phased double speed motors with low energy demand
- Motor designed for continuous operation
- The ball bearings extend the motor service life up to 40,000 hours at non-stop operation
- Fan maintenance is fast and easy due to the removable central block from the casing, which includes the impeller and motor block
- The casing and impeller are made of high quality durable low-flammable ABS
- Also available in fan packs

Speed	Power Supply (V)	Power (W)	Current (A)	Air Delivery (m <sup>3</sup> hr)	Speed (r/min)	Noise (db)
Double Speed	220	95/120	0.45/0.54	830/1050	1770/2450	52/58

Model	oD	B	H	L
ELFPRO200	198mm	240mm	250mm	305mm

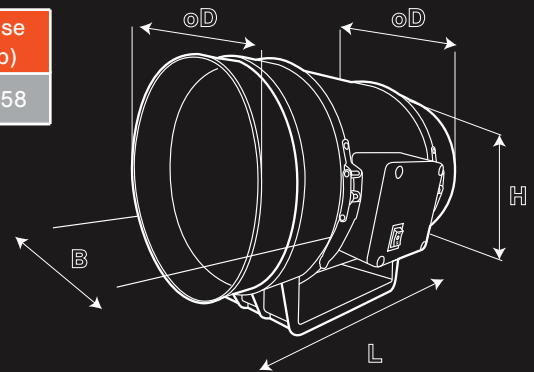

ESC CODE: ELFPRO200